

**INJECTION PUMP**

**UNIT: PUM007**

**PERFORMANCE**

Maximum Operating Pressure	5,000 psi ( 34.5 MPa)
Maximum Flow Rate	1030 m <sup>3</sup> /day

**INJECTION DRIVE**

Model	CAT 3412 C Series
Horse Power	750 HP
Maximum RPM	1800 RPM
Fuel Type	Diesel
Starter Type	Air

**PUMP**

Make	Gardner Denver
Model	PZH (PZ-8)
Plungers	3
Installed Plunger Diameter	6"
Maximum Input	750 HP (559 kW)
Maximum RPM	145 RPM
Stroke Length	8" (203 mm)

**SUCTION PIPING**

Maximum Allowable Working Pressure	285 psi (1965 kPa)
Size	8" (219.1 mm)
Connection	CL150 RF

**DISCHARGE PIPING**

Maximum Allowable Working Pressure	5,000 psi (34.5 MPa)
Size	4" (114.3 mm)
Connection	CL2500 RTJ

**FUEL CONSUMPTION**

50% Load	84.9 L/hr
75% Load	124.3 L/hr
100% Load	159.8 L/hr

\*\*Approximate: Will vary based on site conditions\*\*

**EMISSIONS**

NOx	8.92 g/hp-hr
CO	0.66 g/hp-hr



**SOUND RATING**

<b>Distance</b>	<b>@50%</b>	<b>@100%</b>
In Building	Field Verify dB(A)	Field Verify dB(A)
m ( ft)	Field Verify dB(A)	Field Verify dB(A)
m ( ft)	Field Verify dB(A)	Field Verify dB(A)
m ( ft)	Field Verify dB(A)	Field Verify dB(A)

\*\*Sound ratings will be field verified\*\*

**SHIPPING DIMENSIONS**

Width	12' (3.66 m)
Length	40' 1" (12.21 m)
Height	11' 6" (3.51 m)
Weight Estimate	75,372 lbs (34,260 kg)

**CERTIFICATION**

Drive	Class 1 Zone 2
Pump	API
Piping	ASME B31.3
Electrical	Built to CSA

**POWER REQUIREMENTS**

Building Total	42 kW
Main Disconnect	200 A
Voltage Input	208 V
Phase	3Ø

\*\*Approximate Power Requirements\*\*

**SHUTDOWNS**

Positive Air Shut Down
LEL Shutdown
Over Speed Shutdown

**FEATURES**

2-15kW Roughneck Heaters
Interior Building Lights
Pressure Relief Valve
Inlet Strainer
Air Compressor

# PZH (PZ-8) Triplex Drilling Mud Pump

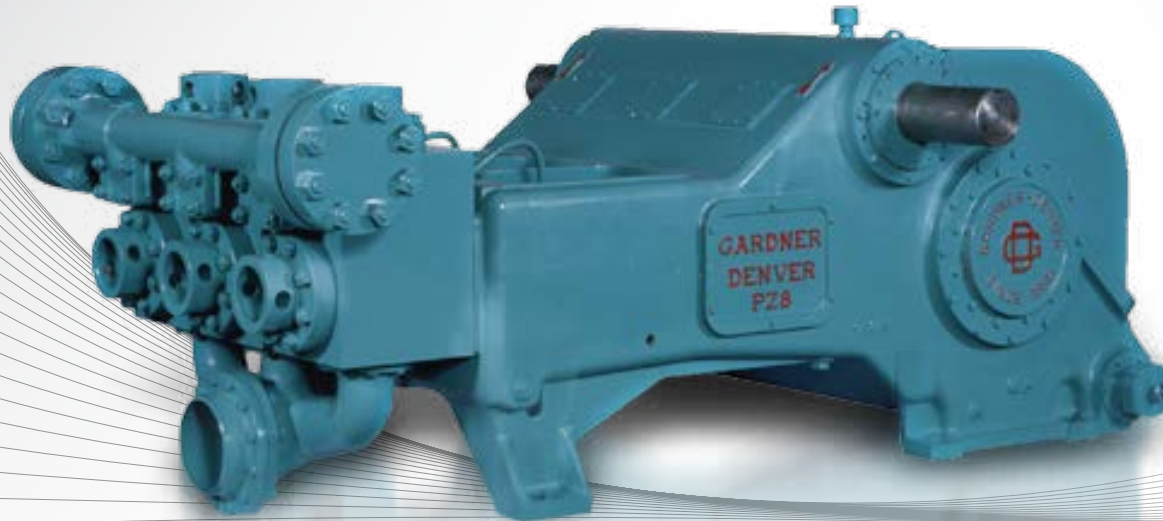

## SPECIFICATIONS

Maximum Input	750 BHP (559 kw)
Maximum RPM	145 RPM
Stroke Length	8" (203 mm)
Piston Load	76,800 (341,623 N)
Pump Weight	19,500 lbs. (8,850 kg)
Gear Ratio	4.5:1

PISTON CYLINDER		DISPLACEMENT – DRILLING SERVICE				MAXIMUM PSI		PUMP RPM	JACKSHAFT RPM
DIAMETER		PER REVOLUTION		MAXIMUM FLOW RATE		PSI	bar		
inch	mm	gallon	liters	GPM	LPM	PSI	bar		
7	178	4.00	15.14	580	2195	1996	138	145	653
6.5	165	3.45	13.05	500	1892	2314	160		
6.25	159	3.19	12.07	462	1750	2503	173		
6	152	2.94	11.12	426	1612	2716	187		
5.5	140	2.47	9.34	358	1355	3232	223		
5	127	2.04	7.72	296	1120	3911	270		
4.5	114	1.65	6.25	240	907	4829	333		
4	102	1.31	4.94	189	717	5000	345		

Weight: Complete pump with large steel skid - 22,500 pounds.

Ratings are based on 90% mechanical efficiency and 100% volumetric efficiency.

**Gardner  
Denver**  
Pumping Perfected.™

# PZH (PZ-8) Triplex Drilling Mud Pump

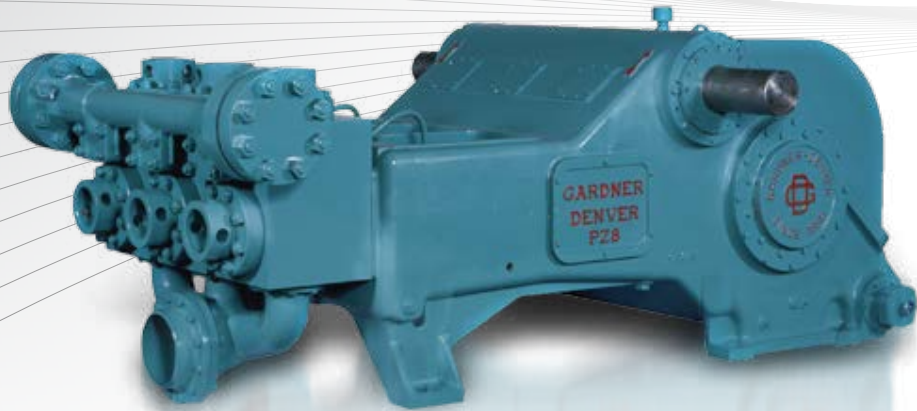

## STANDARD FEATURES

- Nodular iron power framer, eccentric, connecting rods, and crossheads
- Double-row-spherical roller bearings carry eccentric
- Double extended Jackshift carried on heavy-duty straight roller bearings
- Dual roller bearing connecting rod
- Heat-treated alloy steel, interchangeable fluid cylinders
- Three-rib API-7 urethane insert valves and seats
- Replaceable-type element oil filter and oil pressure gauge
- Threaded valve covers
- Complete piston washing and lubrication system

## OPTIONAL FEATURES

- Steel skid under pump only
- Large steel skid with non-skid decking
- Centrifugal suction charging pump
- Rubber valve inserts
- Full open valves
- Suction and/or discharge dampeners
- Oil heat exchanger
- External electric powered lube pump
- Fabricated suction manifold
- Custom packaging available

## SPECIFICATIONS

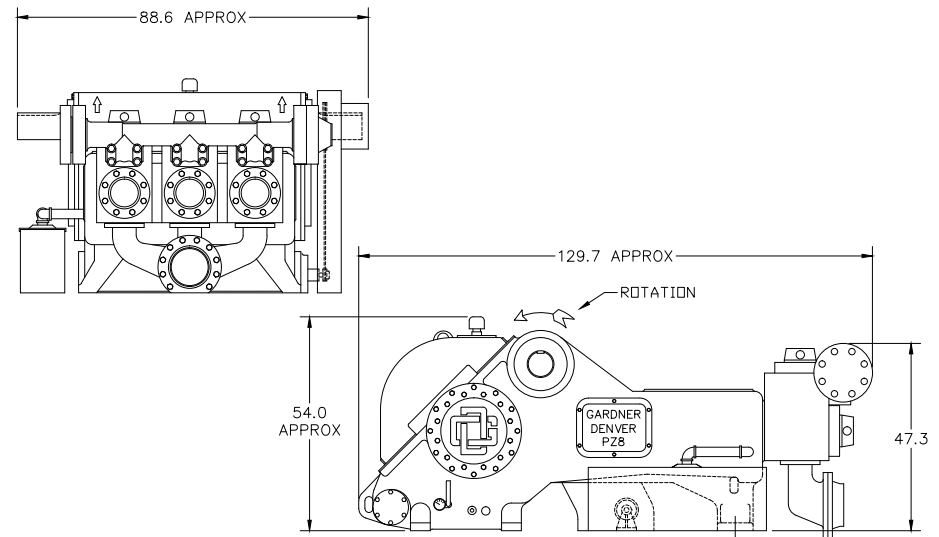

## CONNECT WITH US: