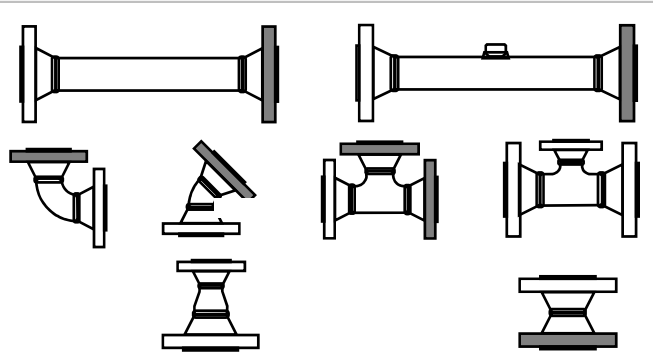

## ASME CL600 FLANGED RENTAL PIPING SPOOLS

### SPECIFICATIONS

Roska Pipe Spec	CSL
Maximum Allowable Working Pressure	1440 psi (9928 kPa)
Minimum/Maximum Rated Operating Temperature	-49°F/135°F (-45°C/57°C)
Pipe Wall Thickness	Schedule 80
Corrosion Allowance	0.063" (1.6 mm)
Radiography	100%, ASME B31.3 Normal Service
Magnetic Particle	100% Fillets, Olets and Branches
Hardness Testing	20% Brinell Hardness Max. 200
Post Weld Heat Treatment	No

### SIZES & CONFIGURATION

Stock Sizes	NPS 2" to 10" <i>Sizes up to NPS 12" Available</i>
Stock Configurations	Straight, Tee, 90°, 45°, Reducing Tee, Reducer, Adaptor
	
	<i>Custom Configurations Available</i>

### CERTIFICATION

Code	ASME B31.3
Province(s) of Registration	AB
Service	Sour