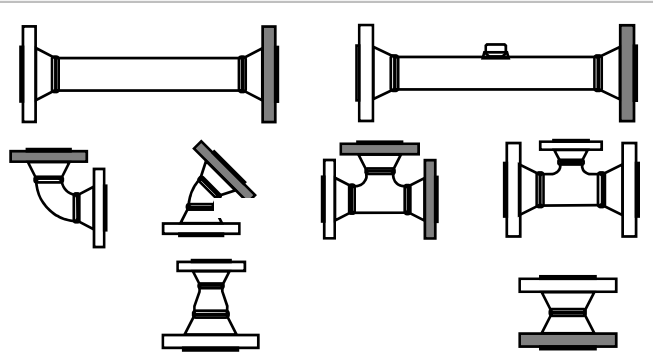

ASME CL150 FLANGED RENTAL PIPING SPOOLS

SPECIFICATIONS

Roska Pipe Spec	ASL
Maximum Allowable Working Pressure	275 psi (1900 kPa)
Minimum/Maximum Rated Operating Temperature	-49°F/135°F (-45°C/57°C)
Pipe Wall Thickness	NPS 2" – 24", Schedule 40
Corrosion Allowance	0.063" (1.6 mm)
Radiography	100%, ASME B31.3 Normal Service
Magnetic Particle	100% Fillets, Olets and Branches
Hardness Testing	20% Brinell Hardness Max. 200
Post Weld Heat Treatment	No

SIZES & CONFIGURATION

Stock Sizes	NPS 2" to 8" <i>Sizes up to NPS 12" Available</i>
Stock Configurations	Straight, Tee, 90°, 45°, Reducing Tee, Reducer, Adaptor
	
	<i>Custom Configurations Available</i>

CERTIFICATION

Code	ASME B31.3
Province(s) of Registration	AB
Service	Sour